

THIS DRAWING IS UNPUBLISHED. RELEASED FOR PUBLICATION
 © COPYRIGHT BY TYCO ELECTRONICS CORPORATION. ALL RIGHTS RESERVED.

LOC	DIST	REVISIONS					
G	86	P	LTR	DESCRIPTION	DATE	DWN	APVD
		A3		REVISED PER ECR-07-017744	04SEP07	HMR	JR

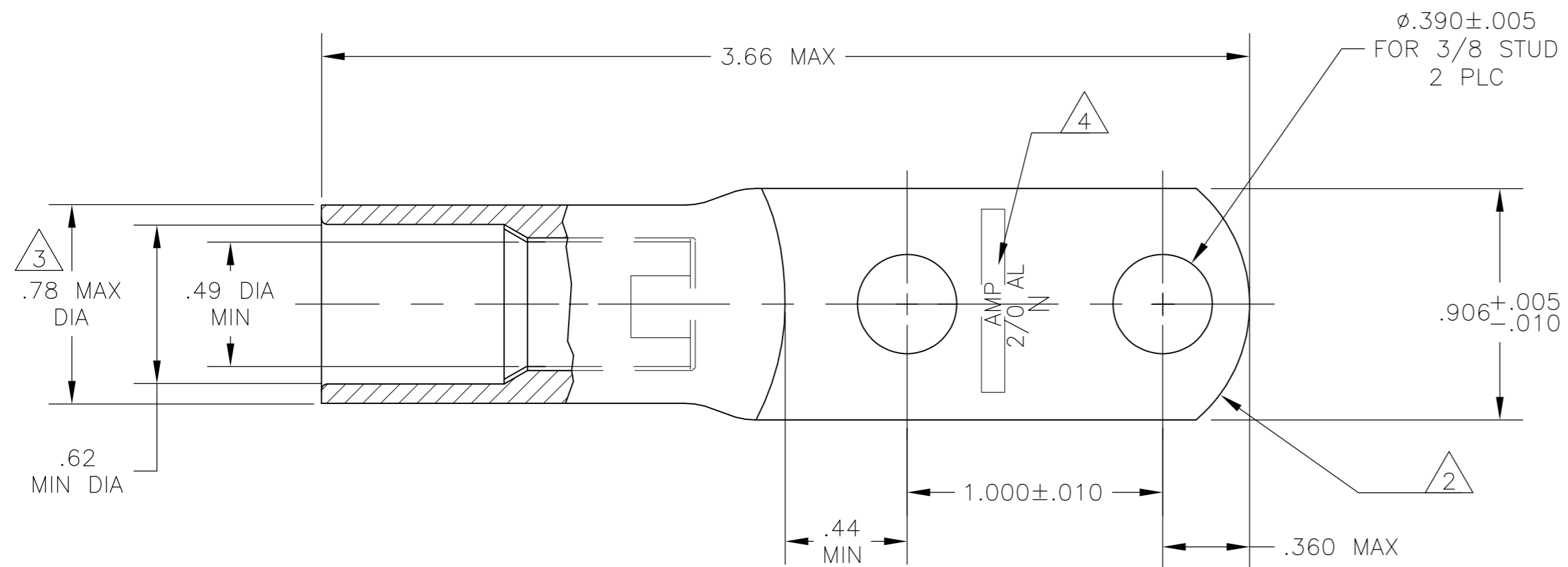

- 1 WIRE INSULATION: .500-.574 DIA
- 2 THE TONGUE RADIUS FEATURE IS NOT A TOOLING CONTROLLED DIMENSION AND MAY NOT BE A TRUE RADIUS.
- 3 FLASH PERMITTED ±.020
- 4 STAMP "AMP 2/0 AL N" SIZE AND LOCATION APPROX AS SHOWN SEE TABLE FOR QUALIFICATION PORTION OF STAMP P = PRODUCTION (IMPACT PART)
- 5 PREPRODUCTION - FASR REQUIRED
- 6 THIS PRODUCT HAS NOT COMPLETED VALIDATION TESTING

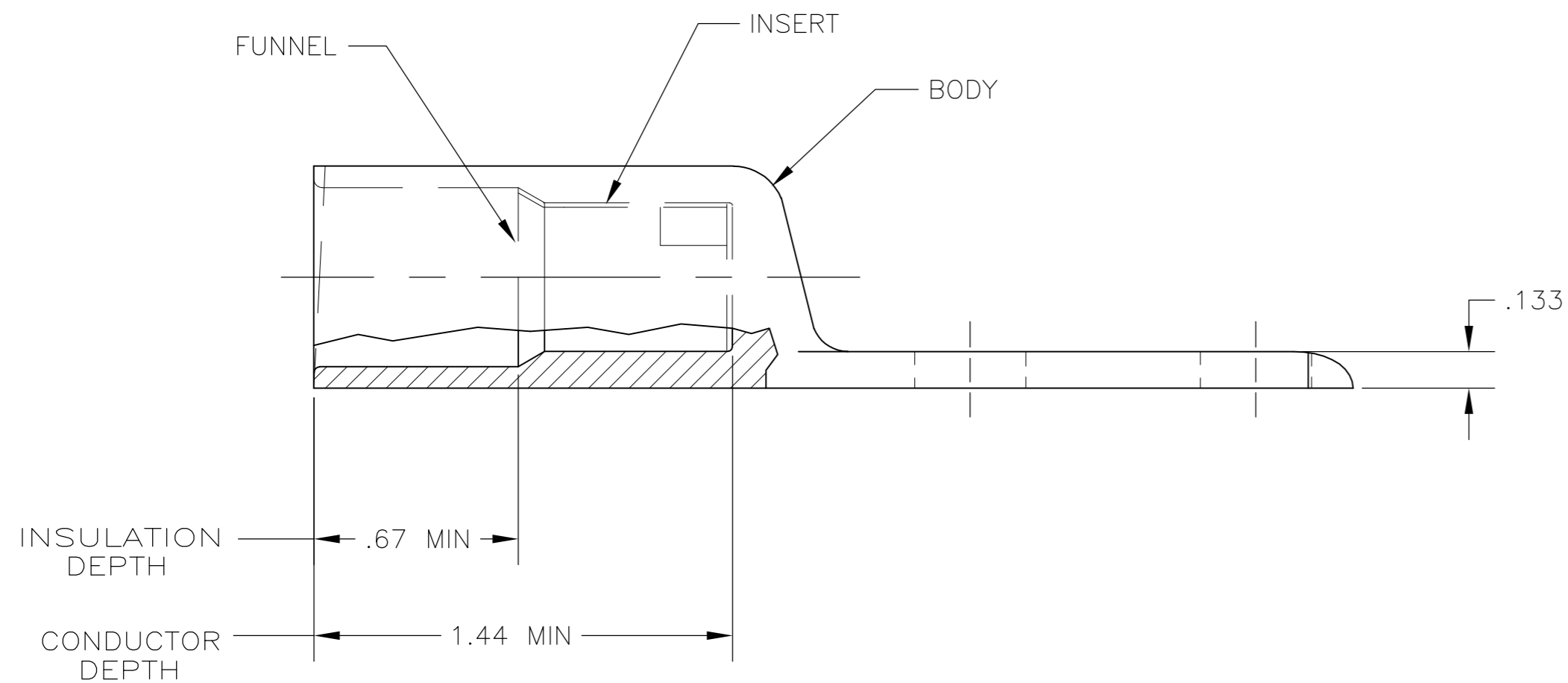

PRODUCTION	P AMP	INSERT & FUNNEL: BRASS MIL-C-50 NICKEL PL QQ-N-290 .000300 AVG THK BODY: COPPER ASTM-B187 ANNEALED NICKEL PL .000300 MIN THK PER QQ-N-290	1958080-1
QUALIFICATION DESCRIPTION	QUALIFICATION STAMP	MATERIAL & FINISH	PART NO.
THIS DRAWING IS A CONTROLLED DOCUMENT.		DWN JR RUTH 31JAN07 CHK JOHN KNOLL 31JAN07 APVD JOHN KNOLL 31JAN07	Tyco Electronics Corporation Harrisburg, PA 17105-3608
DIMENSIONS: INCHES	TOLERANCES UNLESS OTHERWISE SPECIFIED:	NAME	WIRE TERMINAL, RING TONGUE, SEALED COPALUM, WIRE SIZE: 2/0 ALUMINUM
	0 PLC ± - 1 PLC ± - 2 PLC ± - 3 PLC ± .008 4 PLC ± - ANGLES ± -	PRODUCT SPEC	SIZE CAGE CODE DRAWING NO RESTRICTED TO
MATERIAL SEE TABLE	FINISH SEE TABLE	WEIGHT 98 GRAMS	A2 00779 C=1958080
		CUSTOMER DRAWING	SCALE 2:1 SHEET 1 of 1 REV A3